

Solution of Home work # 3

3.2)

(a)

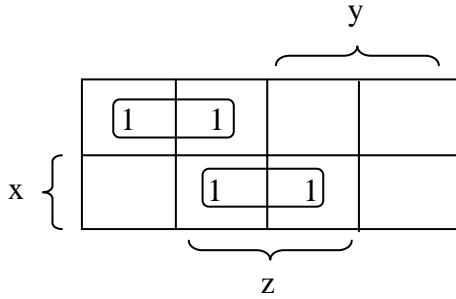

$$F = \sum(0,1,5,7)$$

$$F = x'y' + xz$$

(b)

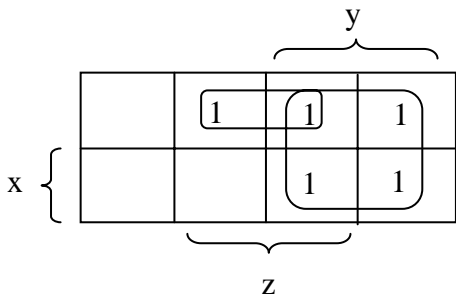

$$F = \sum(1,2,3,6,7)$$

$$F = y + x'z$$

3.7)

(a)

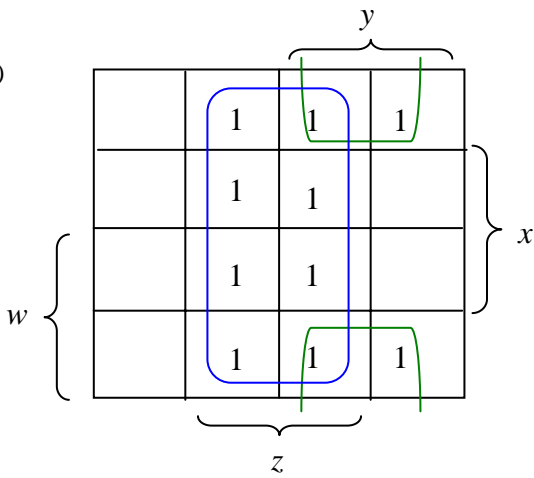

$$F = z + x'y$$

(b)

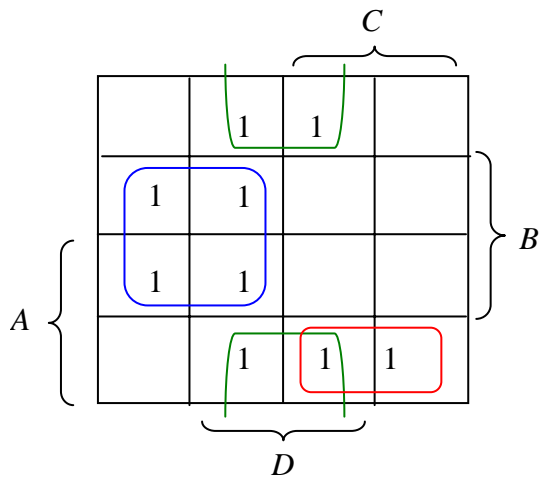

$$F = BC' + B'D + AB'C$$

(c)

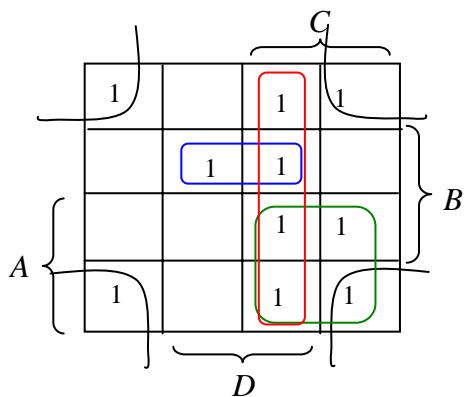

$$F = B'D' + AC + CD + A'BD$$

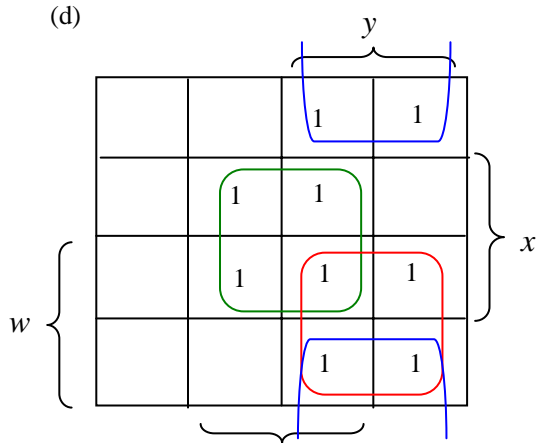

$$F = wy + xz + x'y$$

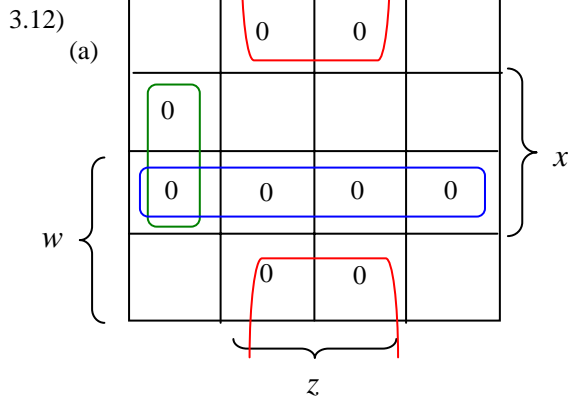

$$F = (w' + x')(x + z')(x' + y + z)$$

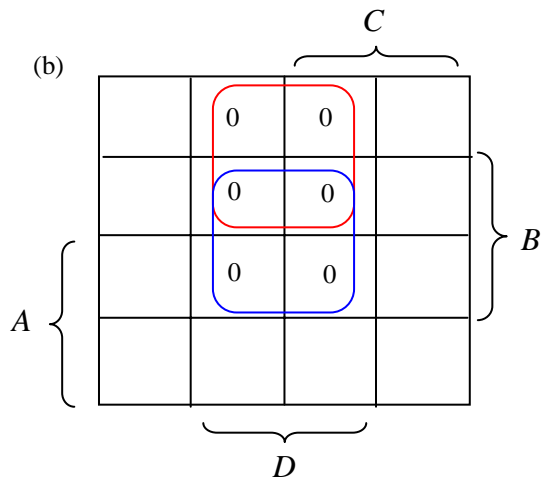

$$F = (A + D')(B' + D')$$

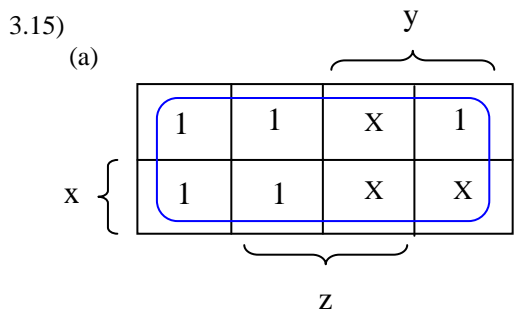

$$F = 1 \equiv \sum(0,1,2,3,4,5,6,7)$$

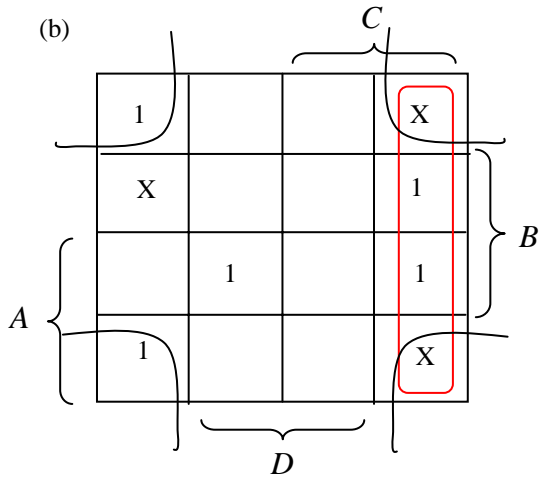

$$F = B'D' + CD' + ABC'D$$

$$= \Sigma(0,2,6,8,10,13,14)$$

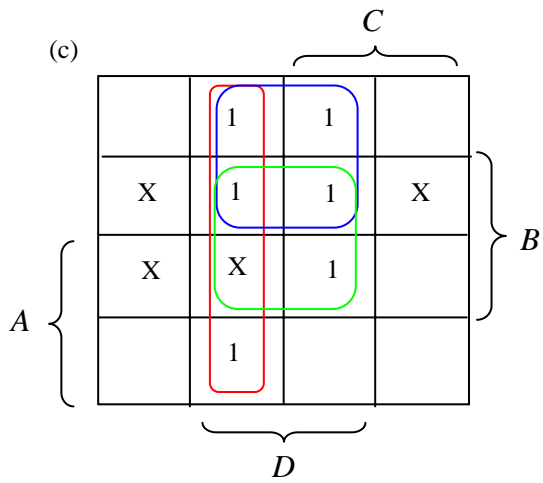

$$F = A'D + BD + C'D$$

$$= \Sigma(1,3,5,7,9,13,15)$$

3.19)

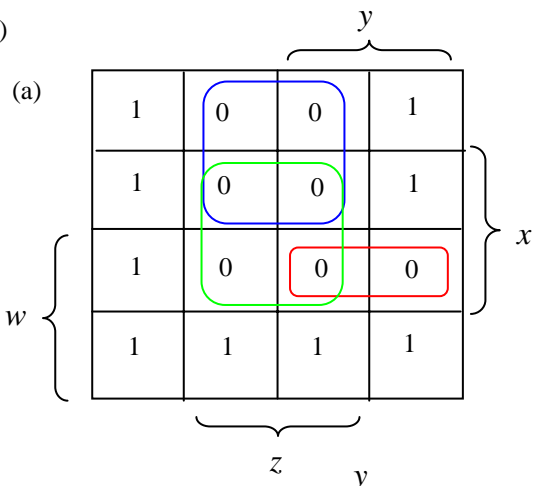

$$F = (x' + z')(w + z')(w' + x' + y')$$

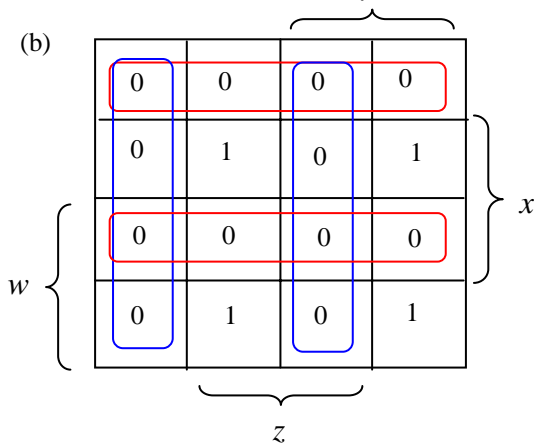
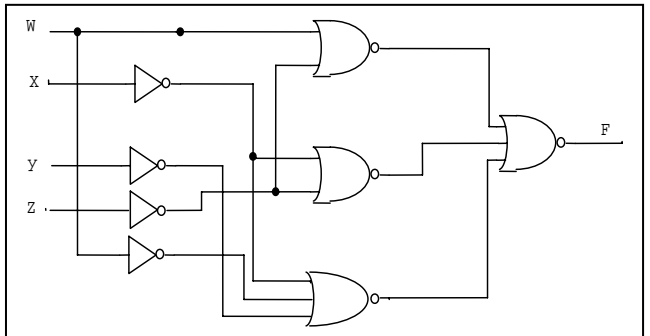

$$F = (w + x)(w' + x')(y + z)(y' + z')$$

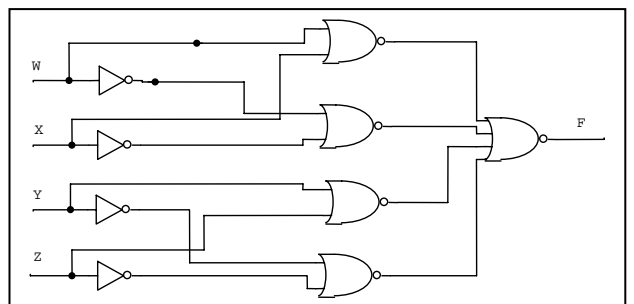

3.31)

```
module Fig_322a (A,B,C,D,F);  
  input A,B,C,D;  
  output F;  
  wire w,x,y,z,Cnot;  
  and (w,C,D);  
  or (x,w,B);  
  and (y,x,A);  
  not (Cnot,C);  
  and (z,B,Cnot);  
  or (F,y,z);  
endmodule
```

3.36)

