

## EE200 DIGITAL LOGIC CIRCUIT DESIGN

### Class Notes CLASS 6-1

The material covered in this class will be as follows:

- ⇒ Prime implicants
- ⇒ Five variables Karnaugh map
- ⇒ Product of sums (POS) simplification
- ⇒ Don't care conditions

### Prime Implicants

We must insure that all minterms of the function are covered using the minimum number of groups. Also redundant terms should be avoided. Sometimes there could be two or more expressions that satisfy the simplification criteria. Prime implicants and essential prime implicants help in organizing the procedure for simplification.

### Prime Implicant

*A product term obtained by combining the maximum possible number of adjacent squares in the map.*

### Essential Prime Implicant

*If a minterm is covered only by a prime implicant, then this prime implicant is called an essential prime implicant.*

## Example

Consider the function :

$$F(A,B,C,D) = \sum(0,2,3,5,7,8,9,10,11,13,15)$$

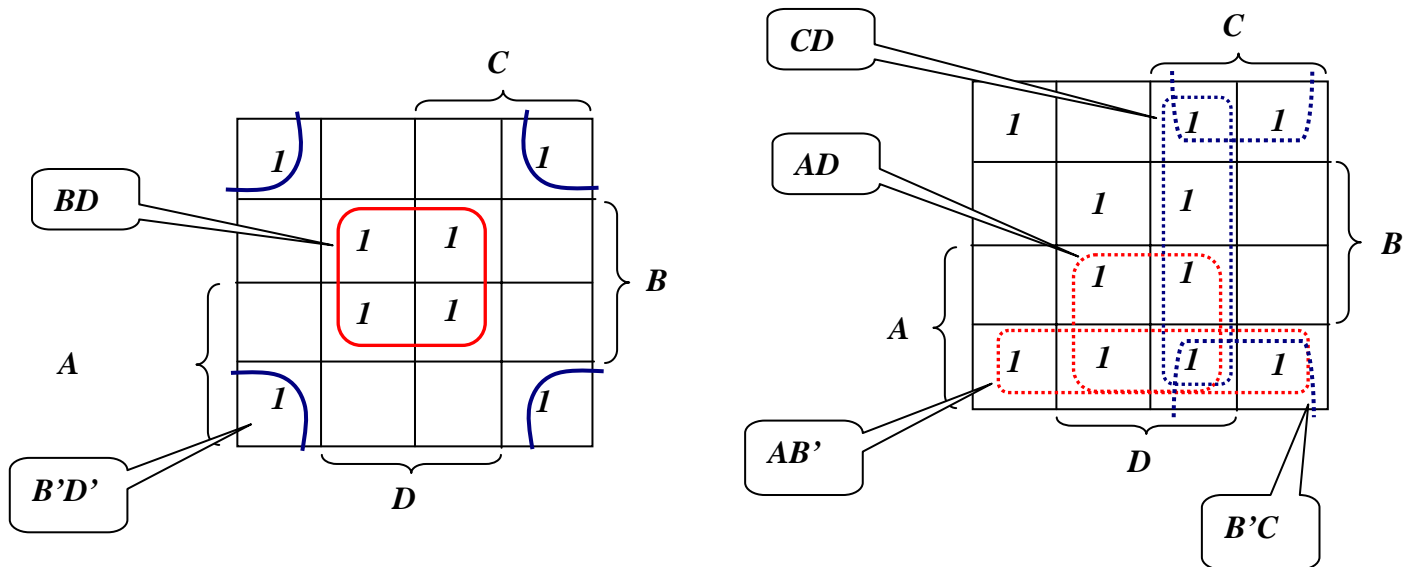

The two essential prime implicants are shown on the left and are:

$$BD \text{ and } B'D'$$

There are also four prime implicants shown on the right. Only two of them can be used to cover the remaining three minterms 3, 9, and 11. These prime implicants are:

$$B'C \text{ and } CD$$

Also,  $AB'$  and  $AD$

The simplified function can take one of four different forms:

$$F = BD + B'D' + CD + AD$$

$$F = BD + B'D' + CD + AB'$$

$$F = BD + B'D' + B'C + AD$$

$$F = BD + B'D' + B'C + AB'$$

### Five Variable Map

The map of five variables is shown below. It consists of two four variable maps.

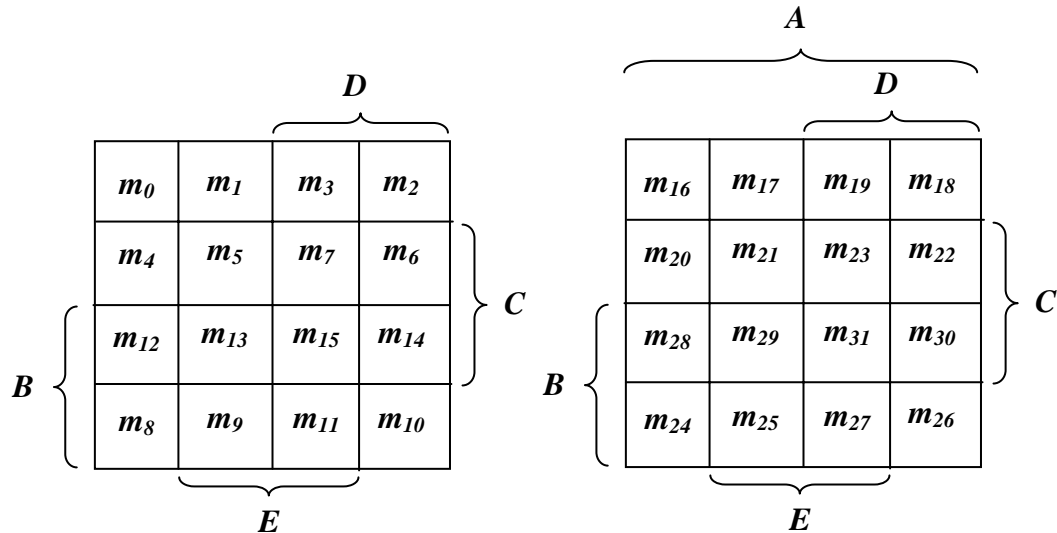

### Example

Simplify the Boolean function

$$F(A, B, C, D, E) = \sum(0, 2, 4, 6, 9, 13, 21, 23, 25, 29, 31)$$

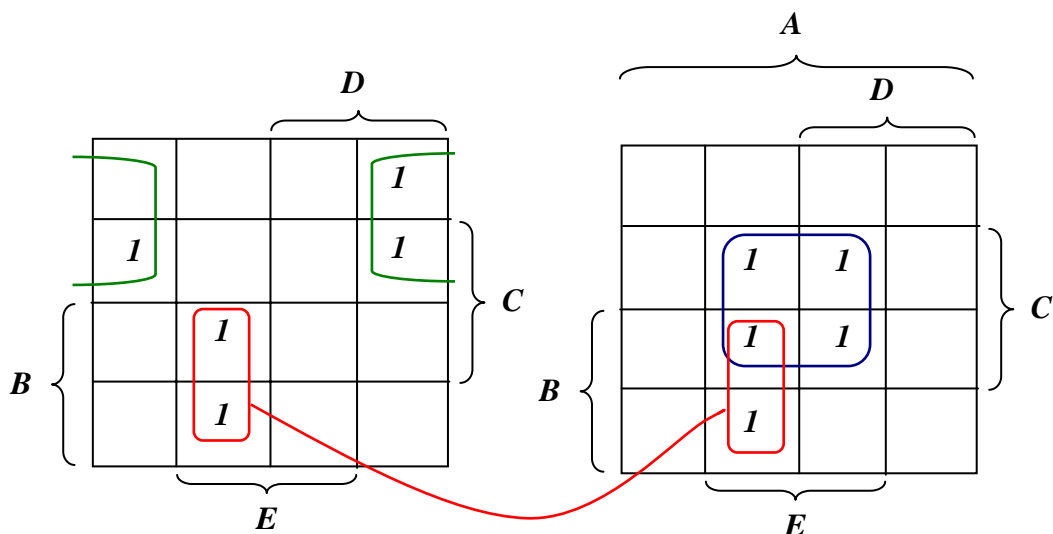

$$F(A,B,C,D,E) = A'B'E' + BD'E + ACE$$

### Product of Sums (POS) Simplification

We combine the zeros of the function to obtain a simplified expression in a POS form. This follows from the fact that the zeros of the function are the ones of the complement of the function.

### Example

Simplify the Boolean function

$$F(A,B,C,D) = \Sigma(0,1,2,5,8,9,10)$$

- a. In SOP form                      b. In POS form.

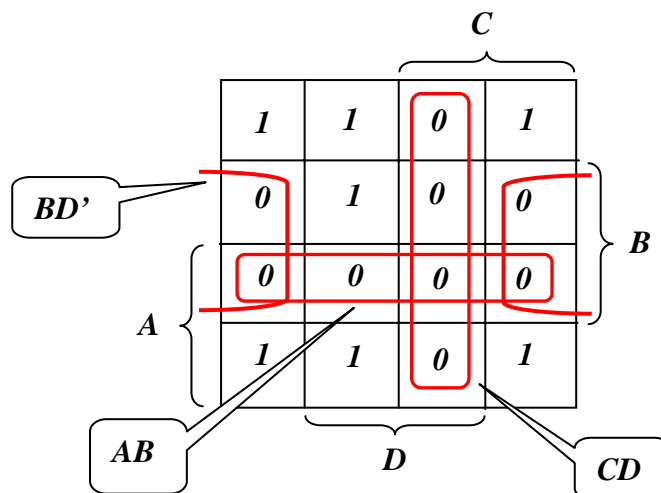

Combining the ones of the function, we get:

$$F = B'C' + B'D' + A'C'D$$

The complement of the function can be expressed in SOP by combining the zeros of the function:

$$F' = AB + CD + BD'$$

We complement the last expression to get the function F in POS form,

$$F = (AB + CD + BD')' = (A' + B')(C' + D')(B' + D)$$

### Don't care conditions

When we design combinational logic circuits, we sometimes encounter situations where combinations of the input variables will never occur. In such cases, we can assume that these conditions can take on the value 1 or 0, whichever goes to give us a simpler expression. These conditions are indicated by letter X or D.

### Example

Simplify the function  $F(w, x, y, z) = \Sigma(1,3,7,11,15)$ , which has the don't care conditions  $d(w, x, y, z) = \Sigma(0,2,5)$

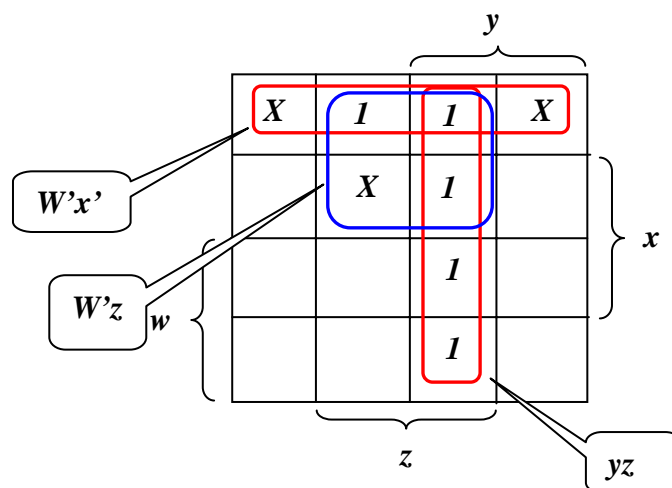

$$F = w'x' + w'z + yz$$